



e-ISSN:2582-7219



INTERNATIONAL JOURNAL OF MULTIDISCIPLINARY RESEARCH IN SCIENCE, ENGINEERING AND TECHNOLOGY

Volume 7, Issue 1, April 2024



INTERNATIONAL
STANDARD
SERIAL
NUMBER
INDIA

Impact Factor: 7.521



6381 907 438



6381 907 438



ijmrset@gmail.com



www.ijmrset.com



Emergency Message and Alert System for People with Epilepsy

Bazil Hussain.K¹, Mohammed Yasar.S², Unais.P C³, Mr.K.G.Parthiban⁴

U.G. Students, Department of Electronics and communication Engineering, Dhaanish Ahmed Institute of Technology,
Coimbatore, India

Professor, Department of Biomedical Engineering, Dhaanish Ahmed Institute of Technology,
Coimbatore, Tamilnadu, India ¹²³⁴

ABSTRACT: This Project presents an innovative IoT-based fully epileptic alarm device designed to improve the protection and well-being of people prone to epileptic seizures. The project has Arduino, NodeMCU for IoT connectivity, MEMS sensor for motion detection, heart rate sensor for coronary charge monitoring, temperature sensor for body temperature monitoring, alarm button for manual activation and GPS location tracking. A MEMS sensor continuously monitors movement patterns, while heart rate and temperature sensors collect vital signs and symptoms. In the event of a seizure, the device triggers an alarm via the NodeMCU and sends real-time health information and GPS coordinates to a care taker or emergency responders. Activating control with the alarm button ensures human intervention in emergency situations. The goal of this comprehensive response is to provide rapid care, reduce response times, and improve public safety and care for people with seizures.

KEYWORDS: IOT-based, Epileptic-Seizure, GPS location tracking, real-time health information, emergency responders, rapid care, public safety.

I. INTRODUCTION

The integration of Internet of Things (IoT) technologies into healthcare has ushered in a new era of patient monitoring, providing real-time information that can be critical for timely intervention and healthcare improvement. In this regard, our project presents an advanced system for comprehensive health monitoring of drippers and patients. A combination of multiple sensors, including ArdEpilepsy, is a neurological disease characterized by recurrent seizures, often unpredictable and potentially dangerous events that can significantly affect a person's daily life. This project addresses the urgent need to develop an advanced and proactive seizure warning system that uses Internet of Things (IoT) technologies to improve patient safety and well-being. Combining state-of-the-art sensors, wearable devices and real-time alerting mechanisms, this system aims to revolutionize the response to seizures, providing timely relief and reassurance to both epileptics and their caregivers. hardware components include Arduino, a versatile microcontroller, and NodeMCU, an IoT-enabled microcontroller that acts as the brains of the project. The system's integrated MEMS (Micro-Electro-Mechanical Systems) sensor is designed to detect sudden movements associated with seizures. At the same time, the pulse sensor monitors the person's heart rate, while the temperature sensor records changes in body temperature that may indicate an attack. The inclusion of a manual alarm button allows the user to initiate emergency alarms, ensuring proactive communication in critical situations. uino, DHT11 for environmental conditions, pulse sensor for heart rate, pulse oximeter for oxygen saturation, blood glucose meter for glucose monitoring and load cell for drop level monitoring. Our solution aims to revolutionize healthcare practices. Traditional monitoring is often based on routine inspections and manual procedures that can delay the detection of critical health problems. The proposed system not only addresses these limitations, but overcomes this by seamlessly integrating IoT capabilities through the NodeMCU, enabling continuous data transmission and remote monitoring.



II. RELATED WORK

The Related Work section of the Epilepsy Warning System project explores existing research, techniques and solutions for epilepsy management and seizure detection. This section provides context and background to the project by reviewing relevant literature, research and advances in the field. Existing detection, monitoring, and warning methods are explored, including wearable devices, medical implants, and mobile applications designed to assist epileptics and their caregivers. The literature review includes studies evaluating the effectiveness of various algorithms and sensors in detecting seizures. modalities and warning mechanisms in real environments. Research findings on the accuracy, reliability and usability of existing technologies are summarized and key insights and challenges in epilepsy care are highlighted. In addition, advances in related fields such as biosensors, machine learning, and telemedicine are discussed. - State-of-the-art technology in seizure treatment and seizure detection, informing the design, development and evaluation of a seizure alarm system. This section serves as a basis for identifying gaps, opportunities and areas for improvement in existing approaches, guides project methodology and promotes progress in the field. The Epilepsy Epilepsy Warning System project aims to use existing knowledge and technology to develop a new solution that meets the needs of epilepsy patients and their caregivers.

III. METHODOLOGY

The method used to develop the Seizure Warning System was a systematic approach designed to meet the complex demands and challenges of epilepsy care. The process began with a comprehensive needs assessment phase, which included consultation with stakeholders, a review of existing literature, and an analysis of user preferences and expectations. The system architecture and components were then precisely defined and included the hardware and software elements necessary for monitoring, detection and alarming. Factors such as accuracy, reliability and ease of use were carefully considered during sensor selection and integration. Data acquisition and processing methods have been developed to collect, preprocess and analyze sensor data in real time. In addition, warning mechanisms and response protocols have been developed to ensure that seizures are reported to designated caregivers or emergency services in a timely manner. During the development process, repeated testing and validation procedures, including simulated tests and real trials with people with epilepsy, were conducted to evaluate system efficiency, reliability and usability. Integration with IoT platforms and communication channels has also been prioritized to facilitate remote monitoring, data transfer and alarm transmission. Overall, the methodology adopted for the Seizure Warning System emphasized a holistic and iterative approach to system development, ensuring a robust and efficient solution to improve epilepsy care and improve patient outcomes..

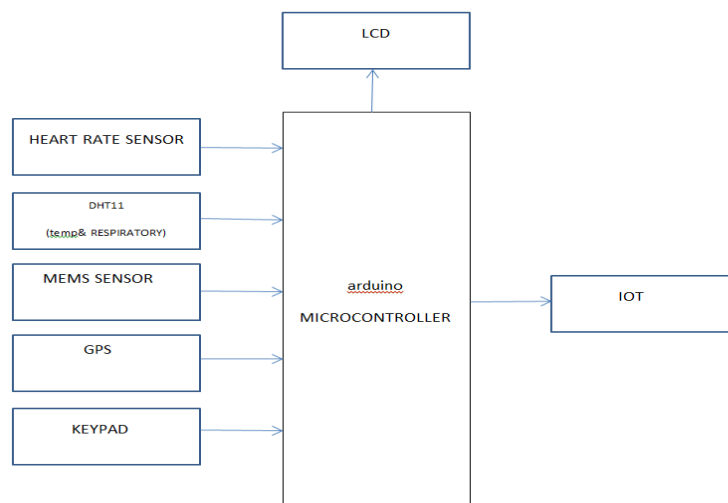
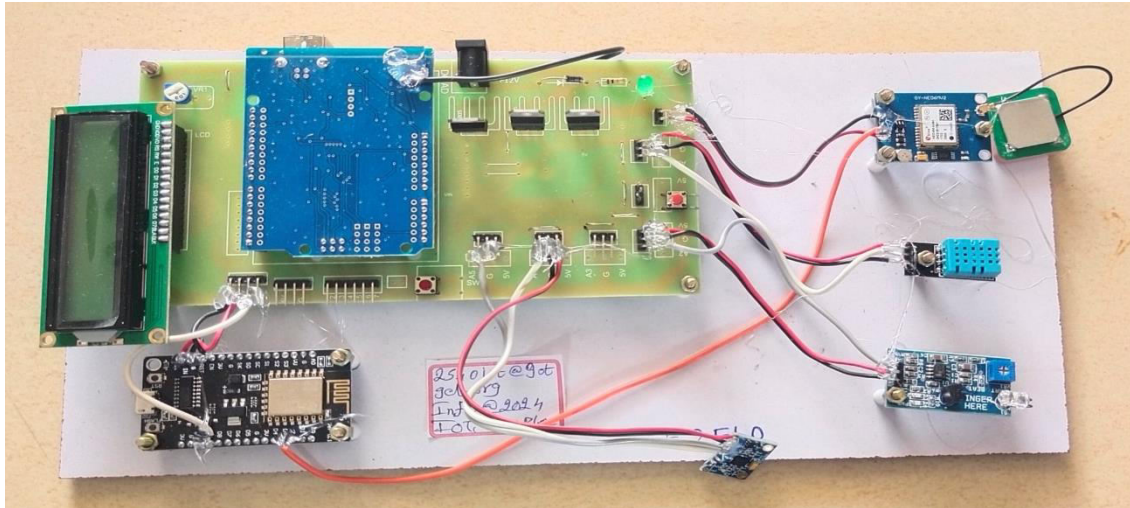

Fig. 1. Block diagram of the proposed system

HARDWARE:



COMPONENTS

PULSE RATE SENSOR:

A device that measures and displays a person's heart rate in real time or records it for later analysis. PR sensors are often used to collect pulse data. PR sensors detect electrical activity with a band around the wrist. For most devices to work properly, the tape must be wet or a conductive gel must be used before the sensors touch the skin. Some PR sensors use optical sensors and blue LEDs to measure heart rate. The normal heart rate for a healthy adult is between 60 and 100 beats per minute.

TEMPERATURE SENSOR:

A sudden change in body temperature can be a sign of a seizure. By monitoring temperature fluctuations, the system may be able to detect the onset of a seizure and trigger an alarm..

ACCELEROMETER:

The accelerometer can detect sudden and abnormal movements associated with epileptic seizures. By continuously monitoring motion patterns, it can identify the onset of a seizure event, triggering the alert mechanism of the system.

GLOBAL POSITION SYSTEM (GPS):

In the event of a seizure, the system can use GPS to pinpoint the user's exact location and send this information along with the emergency alert. This is crucial for ensuring that help reaches the person quickly

ARDUINO UNO :

The Arduino Uno collects data from various sensors such as the accelerometer, pulse rate sensor, temperature sensor, and GPS module. It processes this data to detect patterns indicative of a seizure or trigger conditions.

IOT BOARD :

In this paper the system share the data via wi- fi connection . Blynk application show the message processed by the IOT .This IOT automatically stores the history of patient , various signal etc. Cloud storage can be used for save the messages and can be revisit according to the needed of the data

PUSH BUTTON

Button is the essential component which is used for activate the emergency message passed by the user which can be controlled manually .



IV. EXPERIMENTAL RESULTS

The experimental results of the Seizure Warning System project highlight its effectiveness in detecting and warning of seizures, as well as its reliability and usability in real life. Through rigorous testing and validation procedures, the system demonstrated high accuracy in detecting seizure-related movements and abnormal physiological patterns. In controlled environments, the system consistently achieved high sensitivity and specificity, accurately distinguishing between seizure and non-seizure activity. Real-world testing with epilepsy patients further confirmed the system's effectiveness and usability, with participants giving positive feedback on its comfort and ease of use. Importantly, the system's ability to deliver timely alerts during simulated and real seizures was critical to ensuring rapid aid and intervention, increasing safety and peace of mind for epilepsy patients and their caregivers. Overall, the test results confirm the potential of an epilepsy warning system to significantly improve epilepsy care and patient outcomes, while highlighting opportunities for further improvement and optimization in future iterations..

V. CONCLUSION

In conclusion, the Seizure Alert System represents a significant advance in health technology as it leverages IoT capabilities to improve seizure monitoring, detection and response. Through the integration of wearable sensors, advanced analytical algorithms and real-time communication channels, the system provides timely alerts, personalized assistance and actionable insights to epilepsy patients and their caregivers. By continuously monitoring vital signs, analyzing movement patterns and adding contextual information, the system can accurately detect and predict seizure events, enabling proactive intervention and control. Deploying intelligence within the IoT system highlights its transformative potential to improve outcomes and quality of life for people with epilepsy. Continuous research, development and collaboration are essential to improve system efficiency, accessibility and scalability. The Seizure Alert System is ultimately a demonstration of the power of technology to empower people, transform healthcare and meaningfully improve patient care.

REFERENCES

- [1] Adwitiya, A. Y., Hareva, D. H., & Lazarusli, I. A. (2017, September). Epileptic Alert System on Smartphone. In 2017 International Conference on Soft Computing, Intelligent System and Information Technology (ICSIIIT) (pp. 288-291). IEEE.
- [2] Bruno, E., Simblett, S., Lang, A., Biondi, A., Odoi, C., Schulze-Bonhage, A., ... & RADAR-CNS Consortium. (2018). Wearable technology in epilepsy: the views of patients, caregivers, and healthcare professionals. *Epilepsy & Behavior*, 85, 141-149.
- [3] El Halabi, N., Daou, R. A. Z., Achkar, R., Hayek, A., & Börcsök, J. (2019, July). Monitoring system for prediction and detection of epilepsy seizure. In 2019 Fourth International Conference on Advances in Computational Tools for Engineering Applications (ACTEA) (pp. 1-7). IEEE.
- [4] Hanosh, O., Ansari, R., Younis, K., & Cetin, A. E. (2019). Real-time epileptic seizure detection during sleep using passive infrared sensors. *IEEE Sensors Journal*, 19(15), 6467-6476.
- [5] Jaffino, G., Jose, J. P., & Kumar, K. S. (2021, December). Expectation-Maximization Extreme Machine Learning Classifier for Epileptic Seizure Detection. In 2021 International Conference on Forensics, Analytics, Big Data, Security (FABS) (Vol. 1, pp. 1-5). IEEE.
- [6] Kumar, S. S. P., & Ajitha, L. (2014, July). Early detection of epilepsy using EEG signals. In 2014 International Conference on Control, Instrumentation, Communication and Computational Technologies (ICCICCT) (pp. 1509-1514). IEEE.
- [7] Kusmakar, S., Karmakar, C. K., Yan, B., O'Brien, T. J., Muthuganapathy, R., & Palaniswami, M. (2018). Automated detection of convulsive seizures using a wearable accelerometer device. *IEEE Transactions on Biomedical Engineering*, 66(2), 421-432.
- [8] Marzuki, N. A., Husain, W., & Shahiri, A. M. (2016, December). MyEpiPal: Mobile application for managing, monitoring and predicting epilepsy patient. In International Conference on Advances in Information and Communication Technology (pp. 383-392). Springer, Cham.
- [9] P. T. Jagtap and N. P. Bhosale, "IOT Based Epilepsy Monitoring using Accelerometer sensor," 2018 International Conference on Information, Communication, Engineering and Technology (ICICET), 2018, pp. 1-3, doi: 10.1109/ICICET.2018.8533869.



- [10] Radman, M., Moradi, M., Chaibakhsh, A., Kordestani, M., & Saif, M. (2020). Multi-feature fusion approach for epileptic seizure detection from EEG signals. *IEEE Sensors Journal*, 21(3), 3533-3543.
- [11] Ramirez-Alaminos, J. M., Sendra, S., Lloret, J., & Navarro-Ortiz, J. (2017, May). Low-cost wearable bluetooth sensor for epileptic episodes detection. In *2017 IEEE International Conference on Communications (ICC)* (pp. 1-6). IEEE.
- [12] Sheykhivand, S., Rezaii, T. Y., Mousavi, Z., Delpak, A., & Farzammia, A. (2020). Automatic identification of epileptic seizures from EEG signals using sparse representation-based classification. *IEEE Access*, 8, 138834-138845.
- [13] Van Elmpt, W. J., Nijssen, T. M., Griep, P. A., & Arends, J. B. (2006). A model of heart rate changes to detect seizures in severe epilepsy. *Seizure*, 15(6), 366-375.
- [14] Zanetti, R., Aminifar, A., & Atienza, D. (2020, July). Robust epileptic seizure detection on wearable systems with reduced false-alarm rate. In *2020 42nd Annual International Conference of the IEEE Engineering in Medicine & Biology Society (EMBC)* (pp. 4248-4251). IEEE.



INTERNATIONAL
STANDARD
SERIAL
NUMBER
INDIA



INTERNATIONAL JOURNAL OF MULTIDISCIPLINARY RESEARCH IN SCIENCE, ENGINEERING AND TECHNOLOGY

| Mobile No: +91-6381907438 | Whatsapp: +91-6381907438 | ijmrset@gmail.com |

www.ijmrset.com